



WORLD LEADER IN COMPLETE DIGITAL TEMPLATING SOLUTIONS

PROLINER 10X IS



The Proliner 10X IS is the world's one and only non laser based tracker, combining advanced functionality with rugged reliability. This portable self-contained measuring device can handle any measuring project or location without suffering from environmental influences, such as reflections, fog and dust. The comprehensive integrated CAD software along with the large 10" touch screen display, makes it possible to check, edit and complete measurements on the job site. The Proliner 10X IS is capable of measuring points and contours with high accuracy. With the Integrated Proliner Leapfrog Software, measurements larger than 20 meters can be done very efficiently and accurately.

Professional Dimensioning for Production Improvement

PROLINER 10X IS

WORLD'S MOST FLEXIBLE & EFFICIENT 3D TRACKER & SCANNER

HARDWARE	
Dimensions machine (cm)	38 x 32 x 20
Dimensions touch screen	10"
Tripod fitting hole	double
Internal storage for acc.	double
Water-level sensors	✓
Motion detection	✓
Data storage capacity	8GB (ca. 80.000 DXF files)
RANGE	
Horizontal envelope	360°
Vertical envelope	+ 65 to - 35
Minimum working range	0 m
Maximum working range **	≈ 20 m diameter
ENVIRONMENTAL	
Altitude	-700 to 3000 meters
Humidity	0 to 98% (non-condensing)
Operating temperature	- 10 °C to 50 °C
CONNECTIVITY	
USB	✓
UTP Network socket	✓
Bluetooth	✓
SOFTWARE	
Measuring 2D	✓
Measuring 3D	✓
Leapfrog	✓
Check dimensions	✓
Modify drawing	✓
Generate CAD file (DXF)	✓
POWER SUPPLY	
Cable	✓
Battery	✓

* Specifications, descriptions and technical data may be subject to change

** Without relocating the machine with the onboard leap function

Prodim test protocols are based on ASME B89.4.19-2006

TYPICAL HORIZONTAL SCALE BAR MEASUREMENT*

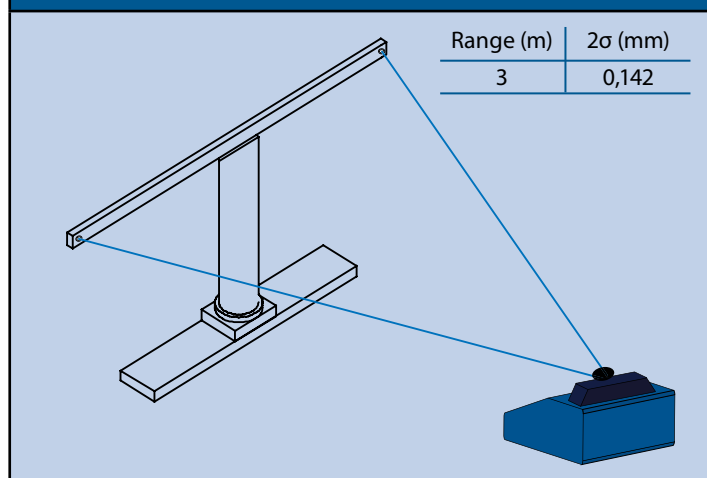

TYPICAL HORIZONTAL RANGE MEASUREMENT*

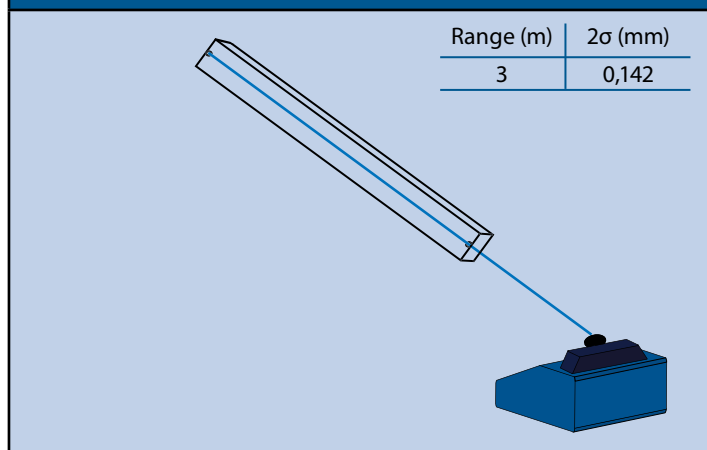

Single point repeatability (2mtrs)*	0,040 mm
SE (3 mtrs)*	0,071 mm

Prodim Calibers
are certified by
VSL, ISO 17025*



Dutch
Metrology
Institute

FOR MORE INFORMATION AND DEMO MOVIES, VISIT OUR WEBSITE:
www.prodim-systems.com

PROLINER[®]
Measurement made portable

Prodim International BV Phone: +31 492 579050
Lagedijk 26, 5705 BZ Helmond, The Netherlands
Prodim USA Phone: +1 772 465 4000
7454 Commercial Cir. Fort Pierce, FL 34951, USA
info@prodim-systems.com

Part of Prodim Group

PRODIM