



WORLD LEADER IN COMPLETE DIGITAL TEMPLATING SOLUTIONS

PROLINER 8X IS



This portable, digital measuring unit is perfect for all measurements in the industry field, like glass, metal, canvas & textile and yachtbuilding. This model is unique in both functionality and appearance and it completes all your measurements on location without any problem. The integrated CAD software and the large 10" wide screen allow users to check dimensions and edit drawings directly on the Proliner on-site. The Proliner 8X IS supports both 2D and 3D versions. To benefit from optimal power flexibility, the Proliner 8X IS comes with rechargeable batteries and a socket adaptor.

Professional Dimensioning *for* Production Improvement

PROLINER 8X IS

THE PERFECT SOLUTION FOR THE INDUSTRY

HARDWARE	
Dimensions machine (cm)	38 x 32 x 18
Dimensions touch screen	10"
Tripod tting hole	double
Internal storage for acc.	double
Water-level sensors	✓
Motion detection	✓
Data storage capacity	8GB (ca. 80.000 DXF files)
RANGE	
Horizontal envelope	360°
Vertical envelope	+ 65° to - 35°
Minimum working range	0 m
Maximum working range **	≈ 14 m diameter
ENVIRONMENTAL	
Altitude	-700 to 3000 meters
Humidity	0 to 98% (non-condensing)
Operating temperature	- 10° C to 50° C
CONNECTIVITY	
USB	✓
UTP Network socket	✓
Bluetooth	✓
SOFTWARE	
Measuring 2D	✓
Measuring 3D	✓
Leapfrog	✓
Check dimensions	✓
Modify drawing	✓
Generate CAD file (DXF)	✓
POWER SUPPLY	
Cable	✓
Battery	✓

* Specifications, descriptions and technical data may be subject to change

** Without relocating the machine with the onboard leap function

Prodim test protocols are based on ASME B89.4.19-2006

TYPICAL HORIZONTAL SCALE BAR MEASUREMENT*

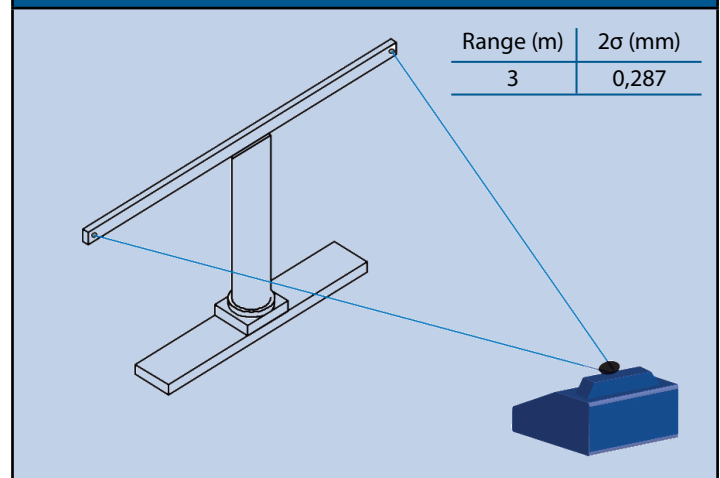

Single point repeatability (2m)*	0,088 mm
SE (3 m)*	0,144 mm

Prodim Calibers
are certified by
VSL, ISO 17025*



FOR MORE INFORMATION AND DEMO MOVIES, VISIT OUR WEBSITE:
www.prodim-systems.com

PROLINER[®]
Measurement made portable

Prodim International BV Phone: +31 492 579050
 Lagedijk 26, 5705 BZ Helmond, The Netherlands
Prodim USA Phone: +1 772 465 4000
 7454 Commercial Cir. Fort Pierce, FL 34951, USA
info@prodim-systems.com

Part of Prodim Group

PRODIM